

机加工滚针轴承

D 50-120mm-RNAO50X65X20

参数信息:

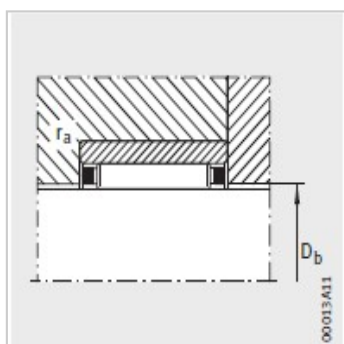
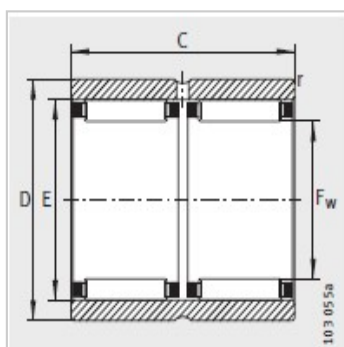
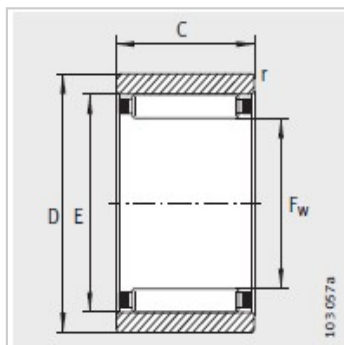

型号 :	RNAO50X65X20
X-life :	XL
质量 g :	168

尺寸mm :

F :	50
D :	65
C :	20
E :	58
r min :	0.3

安装尺寸mm :

D :	50.6
d :	57.2
D :	58.5
r max :	0.3

基本额定载荷N :

动载荷 :	40500
静载荷 :	62000
疲劳极限载荷/N :	10800
极限转速 :	9100
参考转速 :	5600

