

机加工滚针轴承

D 50-120mm- RNAO40X50X17

参数信息:

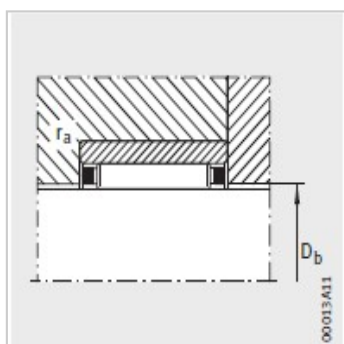
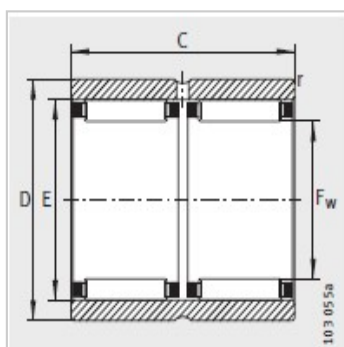
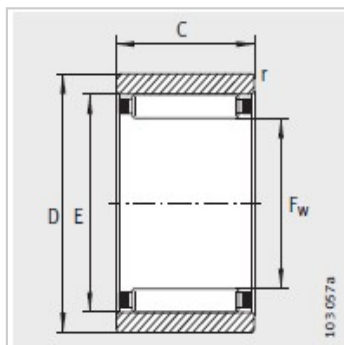

型号 :	RNAO40 X50X17
X-life :	XL
质量 g :	74

尺寸mm :

F :	40
D :	50
C :	17
E :	45
r min :	0.3

安装尺寸mm :

D :	40.6
d :	44.4
D :	45.5
r max :	0.3

基本额定载荷N :

动载荷 :	24200
静载荷 :	41500
疲劳极限载荷/N :	6400
极限转速 :	11500
参考转速 :	7000

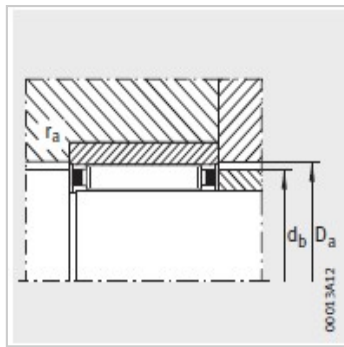

: